

Giusti Vertical Agitation Mixing System

KEY TECHNICAL DATA - YORKWAY, PHARMIX, COSMIX & UNIVERSAL



GIUSTI

APPROVALS

- T Giusti Ltd. is an ISO 9001 registered company
- Pressure vessel approvals include PD 5500, ASME, TUV, APARVE & GOST

NEMA RATING

- All systems are rated at least NEMA 12 (IP55)
- Other standards are available on request

MATERIALS & CONSTRUCTION

- All contact steel is stainless 316L, non-contact steel is stainless 304
- Vessel wall scrapers are PTFE- an FDA approved material
- All internal welds are ground and polished. External body welds are ground smooth and crevice free
- External fillet welds are cleaned and burnished
- Standard finish is satin polish internally and dull polish externally above jacket
- Seismic calculations and construction available at extra cost

VESSEL SIZES

- Standard vessel sizes range from 75 to 6000 litres (see chart below)

- Custom sizes as large as 10,000 litres can be accommodated

AUTOMATION

- All major Automation schemes can be accommodated including Siemens, Allen-Bradley, Mitsubishi & Group Schneider/Square D
- Controls can vary from simple push-button arrangement to fully automated SCADA system
- Siemens HMI (Human Machine Interface) offers simple and effective semi-automated control
- In-house automation engineering

ELECTRICAL

- Supply voltage must be specified between 220-480 volts, 3ph, +n, 50/60hz
- Control circuits are 24v

AGITATION

- Normal maximum speed on contra-agitators is 36 rpm, variable down to 9 rpm. Minimum speed can be variable to 1 rpm by addition of extra cost fixed speed blowers.
- Emulsifier can be single speed (2800 rpm), dual speed (1400/2800 rpm) or variable (700-2800 rpm)

PATENTS

- 'Vapinjet' direct steam injection
- 'Giusti' flush seat valves
- 'Impacton' in line emulsifier

LIDSTYLES

- Flat one piece drop on, 3 piece hinged, fully welded, flange bolted, swing bolted, hinged & clamped or quick release auto

MAINTENANCE/HYGIENE

- Pressure/vacuum vessels capable of full integration into CIP/SIP system
- High up-time, low maintenance

OPERATING PRESSURES

- Standard pressure/vacuum vessels are rated 1 bar or full vacuum inside the vessel, and atmosphere/3 bar in the jacketed void

HEATING & COOLING

- Flooded jacket, Spiral coil, Limpet coil, Dimple jacket or 'Vapinjet' direct steam injection heating
- Mains water, Chilled water or Glycol cooling
- Heating/Cooling under vacuum can produce significant benefits

GIUSTI VERTICAL AGITATION MIXERS - Standard vessel sizing

Litres	75	150	500	1000	1500	2000	3000	4000	5000	6000
US Gallons	20	40	130	265	400	530	795	1055	1320	1585
Dia. Bottom Entry (mm)	25	50	75	75	75	75	75	75	75	75
Dia. Bottom Entry (inches)	1	2	3	3	3	3	3	3	3	3
KW of Inner Agitator Drive	0.75	1.1	2.2	3	4	4	5.5	5.5	7.5	7.5
KW of Outer Agitator Drive	1.1	1.1	3	5.5	5.5	5.5	7.5	7.5	11	11
KW of Optional Emulsifier	4	4	7.5	7.5	11	18.5	18.5	18.5	18.5	18.5

Data is nominal and based on product viscosities between 20,000 & 200,000 cps - SIZING IS HIGHLY PRODUCT DEPENDENT

While every attempt is made to ensure the accuracy of data, Briggs pursues a policy of continuous improvement and reserve the right to change specification without prior notice

Briggs of Burton PLC

Briggs House
Derby Street
Burton on Trent
Staffordshire
UK, DE14 2LH
Phone: +44 (0)1283 566661
Fax: +44 (0)1283 545978
Email: sales@briggspc.co.uk

Briggs of Burton, Inc

400 Airpark Drive
Suite 40
Rochester
New York
USA, NY 14624
Phone: +1 (585) 426 2460
Fax: +1 (585) 426 0250
Email: sales@briggsusa.com

Vertical Agitation Mixing

YORKWAY, PHARMIX, COSMIX & UNIVERSAL



Four designs make up the range of Giusti vertical agitator mixing systems. The **Yorkway** can be supplied from 50 to 6000 litres capacity, has scraped surface agitation and can be supplied with either contra or uni-directional

rotation. Add lid-lift and the designation changes to **Pharmix**. Add vessel tilt and the system becomes **Cosmix**. Move the motor assembly to the base of the unit (for improved top access) and it becomes **Universal**.

All systems can be either Atmospheric or Pressure/Vacuum and have manual, automatic or full PLC control. Custom vessel sizes up to 10,000 litres can be provided.

With over 80 years of process engineering knowledge and a client list that spans the world. From a single simple vessel to a full turnkey facility... **Giusti can help.**

WORLD LEADERS IN PROCESS TECHNOLOGY, SYSTEMS AND PRODUCTS

Giusti are experts in mixing and blending, cooking and cooling, process design and factory automation.

- **INTERNATIONAL FOOD INDUSTRY**
- **TOILETRIES AND COSMETICS**
- **PHARMACEUTICALS**
- **GLOBAL PROJECT MANAGEMENT**
- **ADVANCED AUTOMATION**
- **DEDICATED TESTING FACILITY**

Yorkway

- Wide range of standard sizes from 50 litre to 6,000 litre. Custom sizes up to 10,000 litres can be provided
- Ultra hygienic construction in 316L stainless steel for contact parts; 304 for non-contact parts
- Long-life, easy-maintenance craftsmanship
- All internal welds ground and polished
- 'Bumped' vessel bottoms, not spun, have superior stress and corrosion resistance
- Process flexibility with contra or unidirectional agitation
- Anchor and baffle are independently variable for both speed and direction
- Vessel wall scrapers of low-wear PTFE, an FDA-approved material, give long life, efficient operation and low product contamination risk
- Efficient emulsification with 'bottom entry', 'in-line' or 'triple-shaft' high shear options. Particulate reduction to 10 microns. Two speeds, 1400/2800 rpm, close-meshed rotor/stator design
- Atmospheric or Pressure/Vacuum systems. P/V offers reduced cycle times and improved de-aeration
- All pressure vessels ASME approved
- Extensive vacuum loading expertise; clean, efficient and cost-effective
- Suitable for aseptic production

- Various heating/cooling options. Choose the most cost-effective for your application
- For high water-content products requiring rapid heating times: check the unique Giusti 'Vapinject'. This is an air/steam mixing chamber with injector, fitted through the vessel wall
- Complete range of insulation options to control heat loss and satisfy plant Health & Safety regulations
- Total turnkey facilities: from process engineering and automation to civil engineering as required
- Manual, automatic or full PLC: from simple control to full ERP integration
- In-house automation engineering. All major automation systems covered
- Fully CIP/SIP compatible. Hygiene assured; batch-to-batch times minimised
- Validation documentation as standard. Full IQ/OQ support available
- Viscosities from 1 to 1 million cps, high-shear or low-shear
- We know your application. We have eighty years of process engineering knowledge, a reference list that spans the world and covers many applications!
- Containment options for safe and efficient augment handling
- Flame-proof system options for hazardous environments
- Wide range of drums, lifts and supplementary systems available

Pharmix

- Adds powered lid-lift mechanism

Cosmix

- Includes full vessel-tilt facility for viscous product discharge and easy agitator removal

Universal

- Allows full top access: motor assemblies are at base of system

Giusti Vertical Agitation Mixing System

YORKWAY, PHARMIX, COSMIX & UNIVERSAL

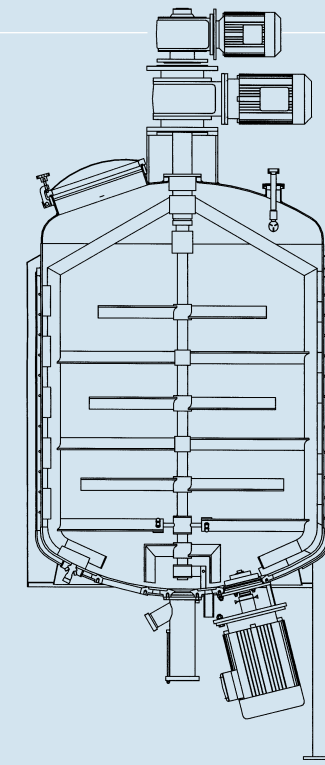

Yorkway - In atmospheric or pressure vacuum styles

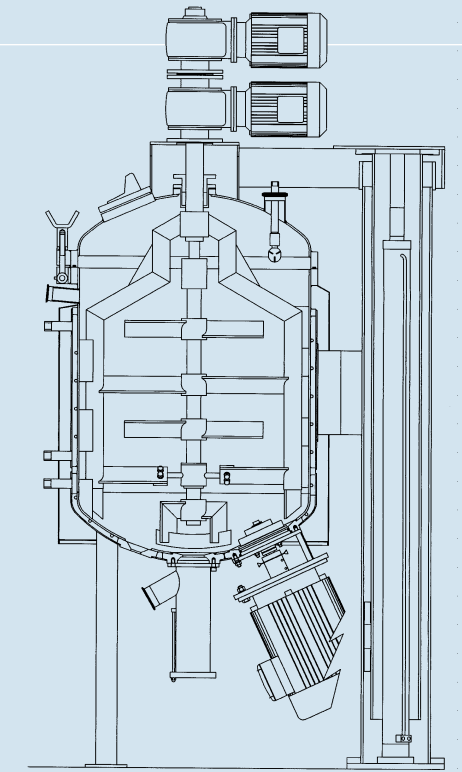

Pharmix - Has hydraulic lid lift for ease of vessel access

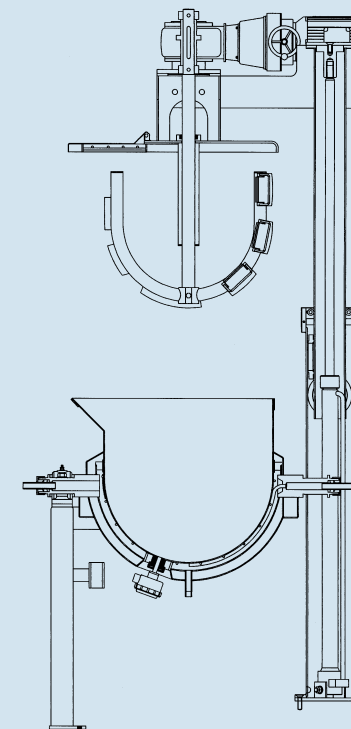

Cosmix - Lidlift & vessel tilt for viscous product discharge

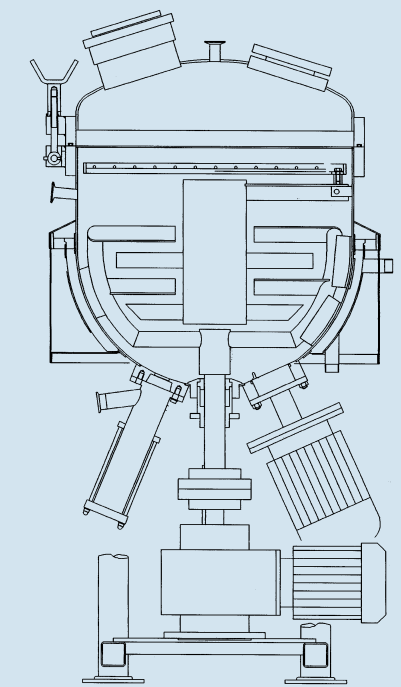

Universal - Motor assembly at base - full top accessibility