

Large Batch Wok

WITH SCRAPED SURFACE AGITATION



The Giusti large batch Wok is targeted at processes that have been traditionally difficult to achieve at production scale – Stir-Fry, Bratting, and Flash Sealing. The Wok is also very useful for sauce reduction.

All food contact parts are 316 stainless steel or FDA approved PEEK. All other construction is 304 stainless steel.

The 1.2 metre diameter pan will cope with batch sizes between 75 and 150 kg. The whole system fits a very compact footprint and requires only 2 metres of headroom. In total it weighs 280 kg unloaded.

The system has full pan tilt to allow discharge to a standard Eurobin or IBC.

The system comes complete with a self contained 48kw oil heater and

offers rapid heat up to 300° C.

The Giusti Wok is very easy to install and maintain – but installation assistance is available if required.

The scraped surface agitation system gives a high degree of product movement in the pan and helps prevent product burn.

Large Batch Wok

KEY TECHNICAL DATA

APPROVALS

- Giusti is an ISO 9001 registered company
- All systems are CE marked

NEMA RATING

- All systems are rated at least NEMA 12 (IP55)
- Other standards are available on request

ELECTRICAL

- Supply voltage must be specified between 220-480 volts, 3ph, +n, 50/60hz
- Control circuits are 24 volts
- All units have emergency stop
- Agitator drive is 1.5kw, fitted with thermistors suitable for inverter drive

MATERIALS & CONSTRUCTION

- All contact steel is stainless 316L, all other steel is stainless 304
- External fillet welds are cleaned and burnished - internal welds are ground and polished
- Standard finish is dull polish
- Scraper blades are high temperature PEEK
- System weight is approximately 280kgs
- Provision is made for floor fixing through 4 holes x 4 pads
- A heavy gauge stainless 316L safety grill is fitted over the cooking pan, hinged at its centre for cleaning

OPERATING

- Heating capacity is 48kw and maximum operating temperature is 350°C
- Oil heater cooling is 'fill and vent', with min/max flow of 140L@3bar/200L@5 bar. Pump is Speck 6091 magnetic drive (or similar). Oil tank is 70 litres capacity (with cooling)
- Tilt facility is hydraulic hand pump assisted
- Batch sizes between 75kg and 150kg
- Only 2 metres of headroom is required to allow full vessel tilt
- Pan is 1.2m diameter and will tilt to only 9° off vertical
- Agitator speed is 36 rpm -variable at extra cost

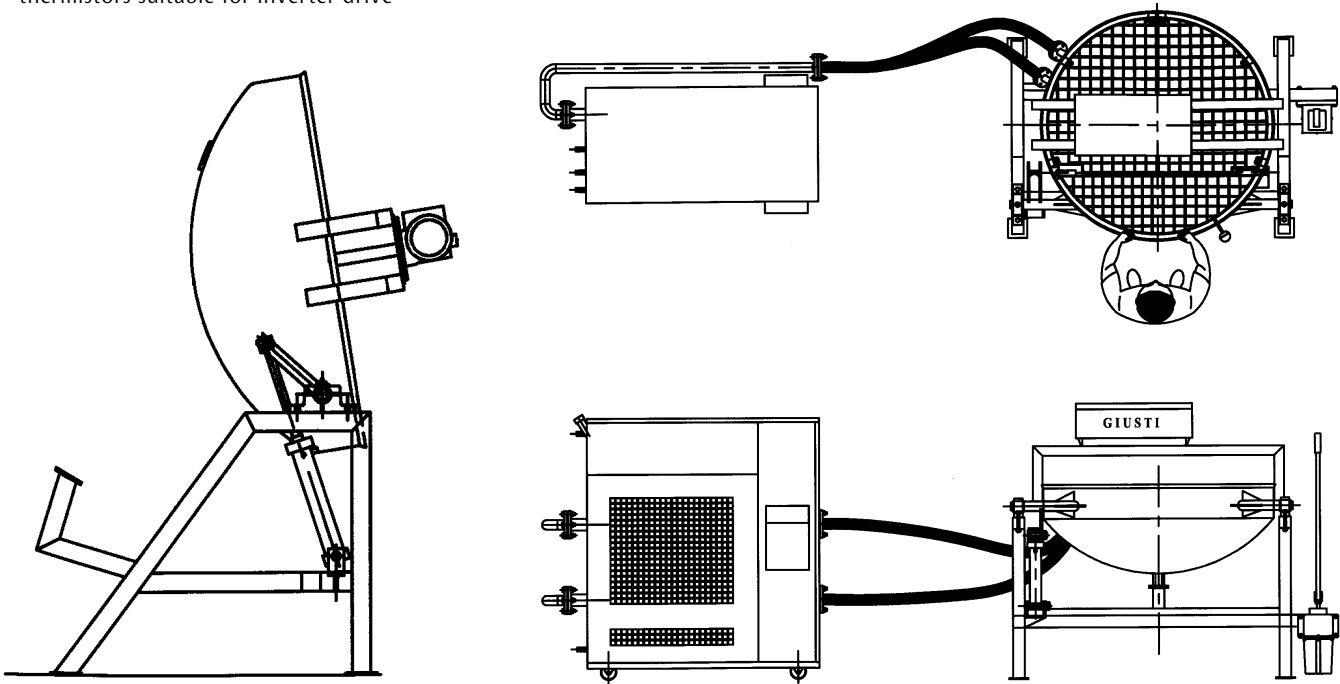

While every attempt is made to ensure the accuracy of data, Briggs pursues a policy of continuous improvement and reserve the right to change specification without prior notice

Briggs of Burton PLC
Briggs House
Derby Street
Burton on Trent
Staffordshire
UK, DE14 2LH
Phone: +44 (0)1283 566661
Fax: +44 (0)1283 545978
Email: sales@briggsplc.co.uk

Briggs of Burton, Inc
400 Airpark Drive
Suite 40
Rochester
New York
USA, NY 14624
Phone: +1 (585) 426 2460
Fax: +1 (585) 426 0250
Email: sales@briggsusa.com

PROCESSING SYSTEMS THAT KNOW NO BOUNDARIES - VISIT OUR WEBSITE: www.giusti.co.uk

GIUSTI & BRIGGS OF BURTON ARE REPRESENTED WORLDWIDE THROUGH OFFICES AND AGENCIES IN EUROPE, THE AMERICAS, INDIA, RUSSIA, CHINA AND AFRICA